

Jablite Limited

Infinity House
Anderson Way
Belvedere
Kent DA17 6BG

Tel: 020 8320 9100 Fax: 020 8320 9110
website: www.jablite.co.uk



Agrément Certificate
87/1796
Product Sheet 4

JABLITE JABFLOOR BOARDS

JABFLOOR PREMIUM 70 AND 100

This Agrément Certificate Product Sheet⁽¹⁾ relates to Jabfloor Premium 70 and 100, expanded polystyrene boards for use as thermal insulation in ground-supported or suspended concrete ground-floors in new and existing domestic buildings.

(1) Hereinafter referred to as 'Certificate'.

CERTIFICATION INCLUDES:

- factors relating to compliance with Building Regulations where applicable
- factors relating to additional non-regulatory information where applicable
- independently verified technical specification
- assessment criteria and technical investigations
- design considerations
- installation guidance
- regular surveillance of production
- formal three-yearly review.



KEY FACTORS ASSESSED

Thermal performance — the declared thermal conductivity (λ_D)* is $0.032 \text{ W}\cdot\text{m}^{-1}\cdot\text{K}^{-1}$, and floors incorporating the products can achieve typical design U values (see section 6).

Condensation — the products can contribute to limiting the risk of condensation (see section 7).

Floor loading — the products, when installed in accordance with this Certificate, can support a design loading for domestic applications (see section 9).

Durability — the products are dimensionally stable and, when installed with the overlays specified, will remain effective as an insulating material for the life of the building in which they are incorporated (see section 11).

The BBA has awarded this Certificate to the company named above for the products described herein. These products have been assessed by the BBA as being fit for their intended use provided they are installed, used and maintained as set out in this Certificate.

On behalf of the British Board of Agrément

A handwritten signature in black ink, appearing to read 'John Albon'.

Date of Second issue: 24 April 2014

John Albon — Head of Approvals
Energy and Ventilation

A handwritten signature in black ink, appearing to read 'Claire Curtis-Thomas'.

Claire Curtis-Thomas
Chief Executive

Originally certified on 12 August 2009

The BBA is a UKAS accredited certification body — Number 113. The schedule of the current scope of accreditation for product certification is available in pdf format via the UKAS link on the BBA website at www.bbacerts.co.uk

Readers are advised to check the validity and latest issue number of this Agrément Certificate by either referring to the BBA website or contacting the BBA direct.

British Board of Agrément
Bucknalls Lane
Watford
Herts WD25 9BA

©2014

tel: 01923 665300
fax: 01923 665301
e-mail: mail@bba.star.co.uk
website: www.bbacerts.co.uk

Regulations

In the opinion of the BBA, Jabfloor Premium 70 and 100, if installed, used and maintained in accordance with this Certificate, can satisfy or contribute to satisfying the relevant requirements of the following Building Regulations (the presence of a UK map indicates that the subject is related to the Building Regulations in the region or regions of the UK depicted):



The Building Regulations 2010 (England and Wales) (as amended)

Requirement:	A1	Loading
Comment:		The products can contribute to satisfying this Requirement. See section 9.2 of this Certificate.
Requirement:	C2(c)	Resistance to moisture
Comment:		The products can contribute to satisfying this Requirement. See sections 7.1 and 7.3 of this Certificate.
Requirement:	L1(a)(i)	Conservation of fuel and power
Comment:		The products can contribute to satisfying this Requirement. See section 6 of this Certificate.
Regulation:	7	Materials and workmanship
Comment:		The products are acceptable. See section 11 and the <i>Installation</i> part of this Certificate.
Regulation:	26	CO ₂ emission rates for new buildings
Regulation:	26A	Fabric energy efficiency rates for new dwellings (England only)
Comment:		The products can contribute to satisfying this Regulation. See section 6 of this Certificate.



The Building (Scotland) Regulations 2004 (as amended)

Regulation:	8(1)	Durability, workmanship and fitness of materials
Comment:		The products are acceptable. See section 11 and the <i>Installation</i> part of this Certificate.
Regulation:	9	Building standards applicable to construction
Standard:	1.1(b)	Structure
Comment:		The products can contribute to satisfying this Standard, with reference to clause 1.1.1 ⁽¹⁾ . See section 9.2 of this Certificate.
Standard:	3.15	Condensation
Comment:		The products can contribute to satisfying this Standard, with reference to clauses 3.15.1 ⁽¹⁾ , 3.15.4 ⁽¹⁾ and 3.15.5 ⁽¹⁾ . See sections 7.1 and 7.4 of this Certificate.
Standard:	6.1(b)	Carbon dioxide emissions
Standard:	6.2	Building insulation envelope
Comment:		The products can contribute to satisfying these Standards, with reference to clauses, or parts of, 6.1.6 ⁽¹⁾ , 6.2.1 ⁽¹⁾ , 6.2.3 ⁽¹⁾ , 6.2.6 ⁽¹⁾ to 6.2.11 ⁽¹⁾ and 6.2.13 ⁽¹⁾ . See section 6 of this Certificate.
Standard:	7.1(a)	Statement of sustainability
Comment:		The products can contribute to satisfying the relevant requirements of Regulation 9, Standards 1 to 6, and, therefore, will contribute to a construction meeting a bronze level of sustainability as defined in this Standard. In addition, the products can contribute to a construction meeting a higher level of sustainability as defined in this Standard with reference to clauses 7.1.4 ⁽¹⁾ Aspects 1 ⁽¹⁾ and 2 ⁽¹⁾ , 7.1.6 ⁽¹⁾ Aspects 1 ⁽¹⁾ and 2 ⁽¹⁾ and 7.1.7 ⁽¹⁾ Aspect 1 ⁽¹⁾ . See section 6.1 of this Certificate.
Regulation:	12	Building standards applicable to conversions
Comment:		Comments made in relation to these products under Regulation 9, Standards 1 to 6 also apply to this Regulation, with reference to clause 0.12.1 ⁽¹⁾ and Schedule 6 ⁽¹⁾ . (1) Technical Handbook (Domestic).



The Building Regulations (Northern Ireland) 2012

Regulation:	23	Fitness of materials and workmanship
Comment:		The products are acceptable. See section 11 and the <i>Installation</i> part of this Certificate.
Regulation:	29	Condensation
Comment:		The products can contribute to satisfying this Regulation. See section 7.1 of this Certificate.
Regulation:	30	Stability
Comment:		The products can contribute to satisfying this Regulation. See section 9.2 of this Certificate.
Regulation:	39(a)(i)	Conservation measures
Regulation:	40(2)	Target carbon dioxide emission rate
Comment:		The products can contribute to satisfying these Regulations. See section 6 of this Certificate

Construction (Design and Management) Regulations 2007

Construction (Design and Management) Regulations (Northern Ireland) 2007

Information in this Certificate may assist the client, CDM co-ordinator, designer and contractors to address their obligations under these Regulations.

See section: 3 *Delivery and site handling* (3.4) of this Certificate.

Additional Information

NHBC accepts the use of Jabfloor Premium 70 and 100, provided they are installed, used and maintained in accordance with this Certificate, in relation to *NHBC Standards*, Chapters 5.1 *Substructure and ground bearing floors* and 5.2 *Suspended ground floors*.

CE marking

The Certificate holder has taken the responsibility of CE marking the products in accordance with harmonised European Standard BS EN 13163 : 2012. An asterisk (*) appearing in this Certificate indicates that data shown is given in the manufacturer's Declaration of Performance.

Technical Specification

1 Description

1.1 Jabfloor Premium 70 and 100 comprise grey EPS 70 and EPS 100 expanded polystyrene boards, manufactured to comply with BS EN 13163 : 2012.

1.2 The boards have the nominal characteristics shown in Table 1.

Table 1 Nominal characteristics

Size (mm)	1200 x 2400
Thickness ⁽¹⁾ (mm)	25, 30, 40, 50, 60, 75, 100, 120, 150 and 200
Nominal density (kg·m ⁻³)	17 (Jabfloor Premium 70) and 20 (Jabfloor Premium 100)
Edge detail	Plain
Minimum compressive stress at 10% deformation (kPa)*	70 (Jabfloor Premium 70) and 100 (Jabfloor Premium 100)

(1) Other sizes available on request.

2 Manufacture

2.1 Jablite Jabfloor Premium insulation products are manufactured from carbon-enriched expanded polystyrene (EPS). The material comprises expandable beads of polystyrene, pre-foamed and fused together in a steam-heated mould under pressure. This produces a block of material, up to 7314 mm long, which is then cut to size and shape.

2.2 As part of the assessment and ongoing surveillance of product quality, the BBA has:

- agreed with the manufacturer the quality control procedures and product testing to be undertaken
- assessed and agreed the quality control operated over batches of incoming materials
- monitored the production process and verified that it is in accordance with the documented process
- evaluated the process for management of nonconformities
- checked that equipment has been properly tested and calibrated
- undertaken to carry out the above measures on a regular basis through a surveillance process, to verify that the specifications and quality control operated by the manufacturer are being maintained.

2.3 The management system of Jablite Limited has been assessed and registered as meeting the requirements of BS EN ISO 9001 : 2008 and BS EN ISO 14001 : 2004 by British Standards Institute (Certificates FM/01260 and EMS/559414).

3 Delivery and site handling

3.1 The products are delivered to site in packs, wrapped in polythene. Each pack contains a label bearing the manufacturer's trade name, product description, board dimensions, quantity of boards and the BBA logo incorporating the number of this Certificate.

3.2 The products must be protected from prolonged exposure to sunlight and should be stored either under cover or protected with opaque light-coloured polythene sheeting.

3.3 The products must be stored fully supported and flat on a firm, level, dry base, protected from the weather and raised above damp surfaces. The products must be discarded if damaged or wet.

3.4 The products must not be exposed to open flame or other ignition sources. Care must be taken to avoid contact with solvents and materials containing organic components.

Assessment and Technical Investigations

The following is a summary of the assessment and technical investigations carried out on Jabfloor Premium 70 and 100.

4 Use

4.1 Jabfloor Premium 70 and 100 are effective in reducing the thermal transmittance (U value) of ground-supported and suspended concrete ground-floors in new and existing domestic buildings.

4.2 Ground-supported concrete and suspended concrete ground-floors incorporating the products must include a suitable damp-proof membrane (dpm) laid beneath the insulation, in accordance with the relevant clauses of CP 102 : 1973 and BS 8215 : 1991 (see sections 13.5 and 13.6 of this Certificate), or suitable ventilation of the sub floor as appropriate.

4.3 The overlay to the insulation boards should be:

- a vapour control layer (VCL) (see section 7.2), and
- a cement-based floor screed, of minimum 65 mm thickness, laid in accordance with the relevant clauses of BS 8204-1 : 2003 and/or BS 8204-2 : 2003, or
- a wood-based floor, eg tongue-and-groove plywood to BS EN 636 : 2012, flooring grade particle board (Types P5 to P7) to BS EN 312 : 2010 or oriented strand board (OSB) of type OSB/3 or OSB/4 to BS EN 300: 2006, of a suitable thickness to be determined by a suitably qualified and experienced individual, installed in accordance with DD CEN/TS 12872 : 2007 and BS EN 12871 : 2010, or
- a concrete slab to BS EN 1992-1-1 : 2004.

5 Practicability of installation

The products are designed to be installed by a competent general builder, or a contractor, experienced with these types of products.

6 Thermal performance

6.1 Calculations of the thermal transmittance (U value) of a floor should be carried out in accordance with BS EN ISO 6946 : 2007, BS EN ISO 13370 : 2007 and BRE Report BR 443 : 2006 using the declared thermal conductivity (λ_D)* value of 0.032 W·m⁻¹·K⁻¹ for Jabfloor Premium 70 and Jabfloor Premium 100.

6.2 The U value of a completed floor will depend on the thickness of the product, the perimeter/area ratio and the floor type. When considering insulation requirements, designers should refer to the detailed guidance contained in the documents supporting the national Building Regulations. Calculated U values for example constructions in accordance with the national Building Regulations are given in Table 2.

Table 2 Floor U⁽¹⁾ values (W·m⁻²·K⁻¹)

Floor type	Perimeter/area ratio	EPS	Minimum insulation thickness (mm)					
			Target U value (W·m ⁻² ·K ⁻¹)					
			0.13	0.15	0.18	0.20	0.22	0.25
Ground supported concrete floor	0.2	Jabfloor Premium 70 and 100	130	100	70	55	40	25
	0.4		175	145	110	95	80	65
	0.6		190	160	125	110	95	80
	0.8		200	165	135	115	105	85
	1		205	170	140	120	110	90
Suspended concrete floor	0.2	Jabfloor Premium 70 and 100	155	125	95	75	60	45
	0.4		185	155	125	105	90	75
	0.6		195	165	135	115	105	85
	0.8		200	175	140	120	110	90
	1		205	175	145	125	110	95

(1) Construction used:

- 300 mm thick perimeter wall with U value of 0.35 W·m⁻²·K⁻¹
- 100 mm concrete slab with conductivity 2.06 W·m⁻¹·K⁻¹ and a minimum 65 mm concrete screed with conductivity 1.15 W·m⁻¹·K⁻¹
- underfloor ventilation area is 0.0015 m²·m (applies to suspended concrete floors only; minimum 150 mm clear ventilated void beneath the floor)
- ground conductivity is 1.5 W·m⁻¹·K⁻¹
- all other parameters are default values from BRE Report BR 443 : 2006.

6.3 The products can contribute to maintaining continuity of thermal insulation at junctions between elements. Example junction details shown in Figure 1 are acceptable and the corresponding ψ -values (psi) in BRE Information Paper IP 1/06, Table 3 may be used in carbon emission calculations in Scotland and Northern Ireland. Detailed guidance for other junctions and on limiting heat loss by air infiltration can be found in:

England and Wales — Approved Documents to Part L and, for new thermal elements to existing buildings, Accredited Construction Details (version 1.0). See also SAP 2009 Appendix X

Scotland — Accredited Construction Details (Scotland)

Northern Ireland — Accredited Construction Details (version 1.0).

Figure 1 Junction between the floor and the wall

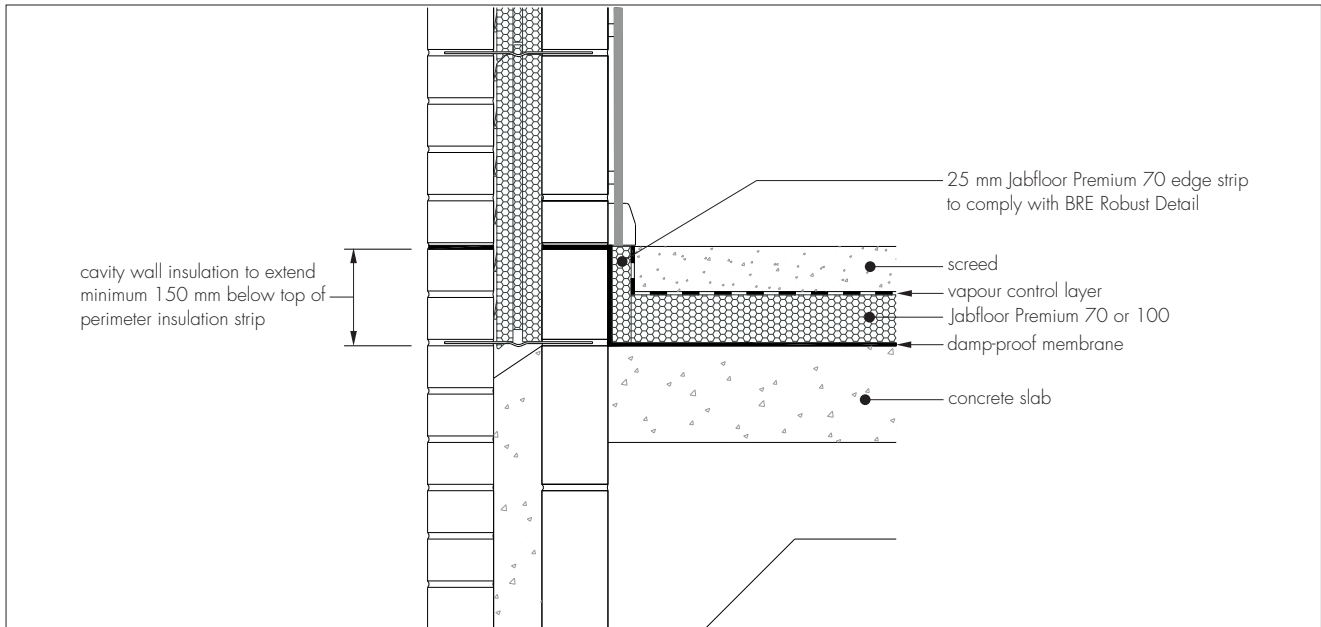

7 Condensation

Interstitial condensation



7.1 Floors will adequately limit the risk of interstitial condensation when they are designed and constructed in accordance with BS 5250 : 2011 Annex F. Jabfloor Premium 70 and 100 have a water vapour resistivity exceeding $100 \text{ MN}\cdot\text{s}\cdot\text{g}^{-1}\cdot\text{m}^{-1}$ and $150 \text{ MN}\cdot\text{s}\cdot\text{g}^{-1}\cdot\text{m}^{-1}$ respectively.

7.2 When the product is used above the dpm on a ground-supported floor, or on a suspended concrete floor, a VCL is installed on the warm side of the insulation to inhibit the risk of interstitial condensation.

Surface condensation



7.3 Floors will adequately limit the risk of surface condensation when the thermal transmittance (U value) does not exceed $0.7 \text{ W}\cdot\text{m}^{-2}\cdot\text{K}^{-1}$ at any point, and the junctions with walls are designed in accordance with the relevant requirements of *Limiting thermal bridging and air leakage: Robust construction details for dwellings and similar buildings* TSO 2002, or BRE Information Paper IP 1/06.



7.4 Floors will adequately limit the risk of surface condensation when the thermal transmittance (U value) does not exceed $1.2 \text{ W}\cdot\text{m}^{-2}\cdot\text{K}^{-1}$ at any point. Guidance may be obtained from BS 5250 : 2011 Annex F and BRE Report BR 262 : 2002.

8 Behaviour in relation to fire

8.1 The products have a Class E* 'reaction to fire' classification in accordance with BS EN 13501-1 : 2007.

8.2 When properly installed, the products will not add significantly to any existing fire hazard. The products will be contained within the floor by the overlay until the overlay itself is destroyed. Therefore, the products will not contribute to the development stages of a fire or present a smoke or toxic hazard.

8.3 Electrical cables running within the polystyrene should be enclosed in a suitable conduit, eg rigid PVC.

9 Floor loading

9.1 The Certificate holder has declared designation codes of CS(10)70* for Jabfloor Premium 70 and CS(10)100* for Jabfloor Premium 100 in accordance with BS EN 13163 : 2012 (compressive stress at 10% deformation to BS EN 826 : 2013).



9.2 The products are suitable for domestic occupancies defined in this Certificate when covered with a suitable floor overlay (see section 4.3) and are capable of resisting a uniformly distributed load of $1.5 \text{ kN}\cdot\text{m}^{-2}$ or a concentrated load of 2 kN for category A1 and A2 (domestic) situations as defined in BS EN 1991-1-1 : 2002, National Annex NA.2, or BS 6399-1 : 1996 Table 1. Further assessment is necessary in the case of duty walkways and floors subject to physical activities.

9.3 The performance of the floor construction will depend on the insulation properties and type of floor covering used (including thickness and strength). Where the products are used under a concrete slab, resistance to concentrated and distributed loads is a function of the slab specification. Further guidance on the suitability of floor coverings can be found in BS EN 13810-1 : 2002, DD CEN/TS 13810-2 : 2003, BS 8204-1 : 2003 and BS EN 312 : 2010, and from the flooring manufacturer.

10 Maintenance

The products are confined within the floor and have suitable durability (see section 11), therefore maintenance is not required.

11 Durability



The products are rot-proof, dimensionally stable and when installed with the overlays specified in this Certificate, will remain effective as an insulating material for the life of the building in which they are incorporated.

12 Reuse and recyclability

Jabfloor Premium expanded polystyrene (EPS) is fully recyclable.

Installation

13 General

13.1 Installation of Jabfloor Premium 70 and 100 must be in accordance with the Certificate holder's installation instructions and the requirements of this Certificate.

13.2 Typical methods are shown in Figures 2 to 4. Reference to the methods should also be made to BRE Report BR 262 : 2002.

Figure 2 Ground-supported concrete floor — concrete slab overlay

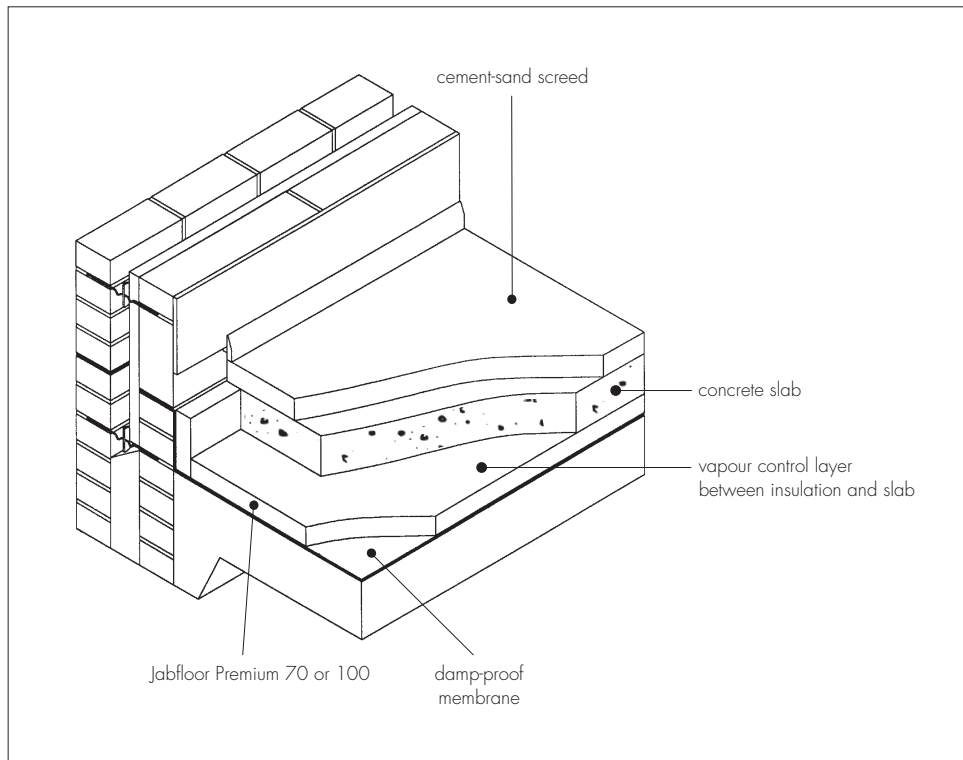

Figure 3 Ground-supported concrete floor — screed overlay

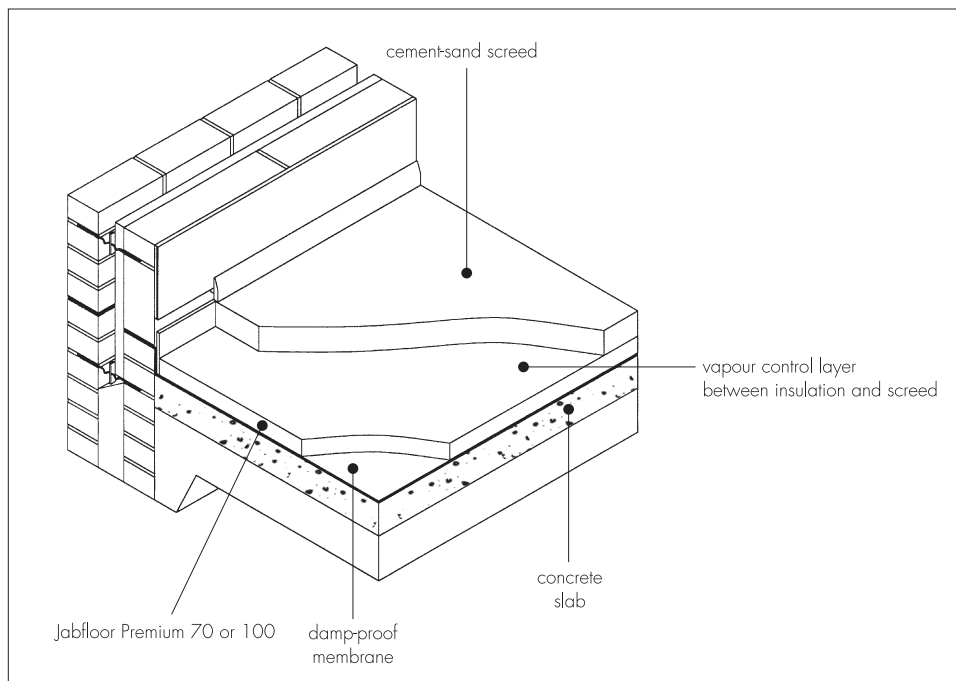
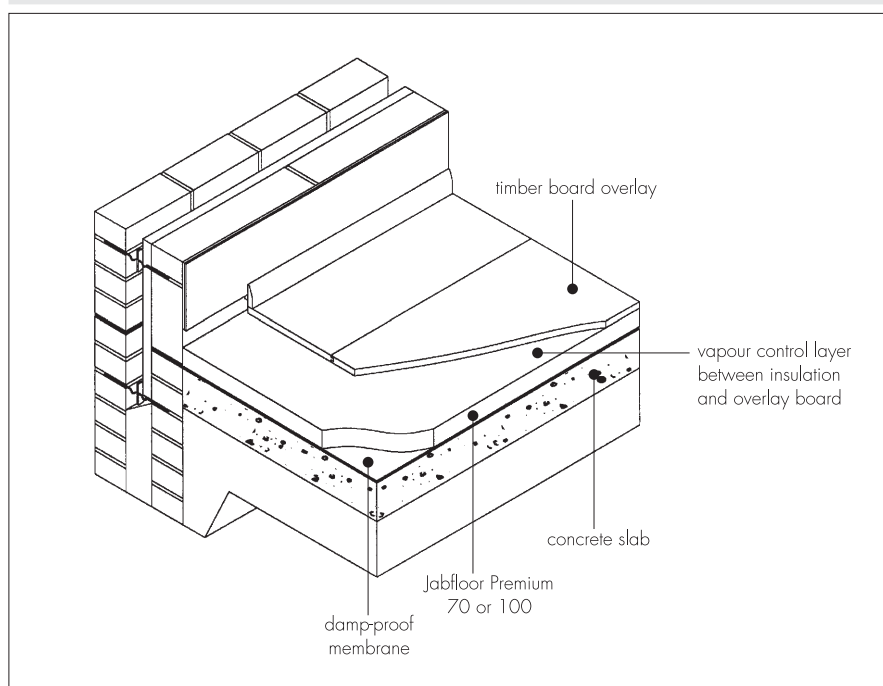

Figure 4 Ground-supported concrete floor — timber board overlay



13.3 All floor surfaces should be smooth, level and flat to within 5 mm when measured with a two metre straight-edge. Irregularities greater than this must be removed. Minor irregularities (up to 10 mm deep) may be levelled with mortar or thin screed.

13.4 In ground-supported concrete floors (see Figures 2 to 4), the concrete floor slab over which the boards are laid should be left for as long as possible to maximise drying out and dissipation of constructional moisture, in accordance with BS 8203 : 2001, Section 3.1.2.

13.5 Where the insulation is used over ground-supported concrete floor slabs, a suitable dpm in accordance with CP 102 : 1973 should be laid to resist moisture from the ground. If a liquid-type damp-proof membrane is applied to the slabs, it should be of a type compatible with expanded polystyrene and be allowed to dry out fully prior to installation of the products.

13.6 Where the insulation is used on hardcore bases beneath ground-supported concrete slabs, the hardcore must be compacted and blinded with a thin layer of sand before application of the dpm, followed by the insulation boards.

13.7 A VCL is installed on the warm side of the insulation to inhibit the risk of interstitial condensation.

13.8 The insulation can be used on suitable beam-and-block suspended concrete floors designed and installed to the precast and general loading codes.

13.9 Where a screed or concrete slab is laid over the insulation, vertical upstands of insulation should be provided and be of sufficient depth to fully separate the screed or slab from the wall. If used, a suitable cavity wall insulation material should be extended below the dpc level to provide edge insulation to the floor.

13.10 To limit the risk of damage from condensation and other sources of dampness, the insulation and overlays should only be laid after the construction is made substantially weathertight, eg after glazing. During construction the insulation and overlay must also be protected from damage by traffic and moisture sources such as water spillage, and plaster droppings.

14 Procedure

14.1 The products are cut to size (using a sharp knife or fine toothed saw) and laid with closely-buttet, staggered cross-joints, ensuring that all spaces are completely filled.

14.2 The laying pattern should ensure that all cut edges are at the perimeter of the floor or some other feature, eg matwells, thresholds or access ducts. Spreader boards should be used to protect the insulation.

Timber-based board overlay (Figure 4)

14.3 Before laying the plywood, particle board or OSB overlays, preservative-treated timber battens, in accordance with BS 8417 : 2011, are positioned at doorways and access panels. Adequate time should be allowed for preservatives to be fixed and the solvents from solvent-based preservatives to evaporate.

14.4 Where the insulation is laid above a dpm, a polyethylene VCL with a minimum thickness of 0.125 mm (500 gauge) is laid between the insulation and the timber board overlay. The VCL should have 150 mm overlaps, taped at the joints, and be turned up 100 mm at the walls.

14.5 Timber-based overlay boards (see section 4.3) are laid with staggered cross-joints, in accordance with DD CEN/TS 12872 : 2007 and BS EN 12871 : 2010.

14.6 An expansion gap between the overlay board and the perimeter walls should be provided at the rate of 2 mm per metre run or a minimum of 10 mm, whichever is the greater.

14.7 Where there are long, uninterrupted lengths of floor, eg corridors, proprietary expansion joints should be installed at intervals, on the basis of a 2 mm gap per metre run of overlay board.

14.8 Before the overlay boards are interlocked, a waterproof PVA adhesive is applied to the joints.

14.9 Once the overlay board is laid, temporary wedges are inserted between the walls and the floor to maintain tight joints until the adhesive has set.

14.10 When the wedges are removed and before the skirting boards are fixed, suitable compressible filler, eg foamed polyethylene, should be fitted around the perimeter of the floor between the overlay board and the walls.

14.11 Where there is a likelihood of regular water spillage (eg in kitchens, bathrooms, shower and utility rooms), additional particle board protection should be considered, eg by a continuous flexible vinyl sheet flooring, with welded joints, turned up at abutments and cove skirting.

Cement-based screed overlay (Figure 3)

14.12 Perimeter edge pieces are cut and placed around the edges and taped at joints. A polyethylene VCL, minimum 0.125 mm thick (500 gauge), is laid over the insulation. The VCL should have 150 mm overlaps, taped at the joints, and be turned up 100 mm at the walls. A properly-compacted screed of a minimum 65 mm thickness is then laid over. The relevant clauses of BS 8204-1 : 2003 should be followed.

Concrete slab overlay (ground-bearing only) (Figure 2)

14.13 Perimeter edge pieces are cut and placed around the edges and taped at joints. A polyethylene VCL, minimum 0.125 mm thick (500 gauge), is laid over the insulation. The VCL should have 150 mm overlaps, taped at the joints, and be turned up 100 mm at the walls. The concrete slab is laid to the required thickness in accordance with BS 8000-9 : 2003 and BS 8204-1 : 2003.

15 Incorporation of services

15.1 De-rating of electrical cables should be considered where the insulation restricts air cooling of cables; the boards must not be used in direct contact with electrical heating cables or hot water pipes.

15.2 Where possible, electrical conduits, gas and water pipes or other services should be contained within ducts or channels within the concrete slab of ground supported floors. Where this is not possible, the services may be accommodated within the insulation, provided they are securely fixed to the concrete slab. Electrical cables should be enclosed in a suitable conduit. With hot pipes, the insulation must be cut back to maintain an air space.

15.3 Where water pipes are installed, either within the slab or the insulation, they must be pre-lagged with close-fitting pipe insulation eg extruded polyethylene foam.

15.4 Where the product is installed on a floor of a suspended beam and block design, all services must be installed so as not to impair the floor performance.

15.5 On overlay board floors, in situations where access to the services is desirable, a duct may be formed by mechanically fixing to the floor, timber bearers of the same thickness as the insulation to provide support for a particle board cover. The duct should be as narrow as possible and not exceed 400 mm in width or the maximum particle board spans given in DD CEN/TS 12872 : 2007 without intermediate support. Services should be suitably fixed to the floor base and not to the insulation boards.

Technical Investigations

16 Tests

As part of the assessment resulting in the issue of a previous Certificate, tests were carried out to determine:

- compressive stress at 10% deformation
- thermal conductivity
- density
- dimensional accuracy.

17 Investigations

17.1 The manufacturing process of Jabfloor Premium 70 and Jabfloor Premium 100 was evaluated, including the methods adopted for quality control, and details were obtained of the quality and composition of the materials used.

17.2 A re-examination was made of the data and investigations on which previous Certificates were based. The conclusions drawn from the original data remain valid.

17.3 Existing data relating to the thermal insulation properties and equilibrium moisture content of the material were examined.

17.4 An assessment of the risk of interstitial condensation was made.

Bibliography

BS 5250 : 2011 *Code of practice for control of condensation in buildings*

BS 6399-1 : 1996 *Loading for buildings — Code of practice for dead and imposed loads*

BS 8000-9 : 2003 *Workmanship on building sites — Cementitious levelling screeds and wearing screeds — Code of practice*

BS 8203 : 2001 *Code of practice for installation of resilient floor coverings*

BS 8204-1 : 2003 *Screeds, bases and in-situ floorings — Concrete bases and cement sand levelling screeds to receive floorings — Code of practice*

BS 8204-2 : 2003 *Screeds, bases and in-situ floorings — Concrete wearing surfaces — Code of practice*

BS 8215 : 1991 *Code of practice for design and installation of damp-proof courses in masonry construction*

BS 8417 : 2011 *Preservation of wood — Code of practice*

BS EN 300 : 2006 *Oriented Strand Boards (OSB) — Definitions, classification and specifications*

BS EN 312 : 2010 *Particleboards — Specifications*

BS EN 636 : 2012 *Plywood — Specifications*

BS EN 826 : 2013 *Thermal insulating products for building applications — Determination of compression behaviour*

BS EN 1991-1-1 : 2002 *Eurocode 1 : Actions on structures — General actions— Densities, self-weight, imposed loads for buildings*

NA to BS EN 1991-1-1 : 2002 *UK National Annex to Eurocode 1 : Actions on structures — General actions — Densities, self-weight, imposed loads for buildings*

BS EN 1992-1-1 : 2004 *Eurocode 2 : Design of concrete structures — General rules and rules for buildings*

BS EN 12871 : 2010 *Wood-based panels — Performance specifications and requirements for load bearing boards for use in floors, walls and roofs*

BS EN 13163 : 2012 *Thermal insulation products for buildings — Factory made expanded polystyrene (EPS) products — Specification*

BS EN 13501-1 : 2007 *Fire classification of construction products and building elements — Classification using test data from reaction to fire tests*

BS EN 13810-1 : 2002 *Wood-based panels — Floating floors — Performance specifications and requirements*

BS EN ISO 6946 : 2007 *Building components and building elements — Thermal resistance and thermal transmittance — Calculation method*

BS EN ISO 9001 : 2008 *Quality management systems — Requirements*

BS EN ISO 13370 : 2007 *Thermal performance of buildings — Heat transfer via the ground — Calculation methods*
BS EN ISO 14001 : 2004 *Environmental management systems — Requirements with guidance for use*
CP 102 : 1973 *Code of practice for protection of buildings against water from the ground*
DD CEN/TS 12872 : 2007 *Wood-based panels — Guidance on the use of load-bearing boards in floors, walls and roofs*
DD CEN/TS 13810-2 : 2003 *Wood-based panels — Floating floors — Test methods*
BRE Information Paper IP 1/06 *Assessing the effects of thermal bridging at junctions and around openings*
BRE Report (BR 262 : 2002) *Thermal insulation: avoiding risks*
BRE Report (BR 443 : 2006) *Conventions for U-value calculations*

Conditions of Certification

18 Conditions

18.1 This Certificate:

- relates only to the product/system that is named and described on the front page
- is issued only to the company, firm, organisation or person named on the front page — no other company, firm, organisation or person may hold or claim that this Certificate has been issued to them
- is valid only within the UK
- has to be read, considered and used as a whole document — it may be misleading and will be incomplete to be selective
- is copyright of the BBA
- is subject to English Law.

18.2 Publications, documents, specifications, legislation, regulations, standards and the like referenced in this Certificate are those that were current and/or deemed relevant by the BBA at the date of issue or reissue of this Certificate.

18.3 This Certificate will remain valid for an unlimited period provided that the product/system and its manufacture and/or fabrication, including all related and relevant parts and processes thereof:

- are maintained at or above the levels which have been assessed and found to be satisfactory by the BBA
- continue to be checked as and when deemed appropriate by the BBA under arrangements that it will determine
- are reviewed by the BBA as and when it considers appropriate.

18.4 The BBA has used due skill, care and diligence in preparing this Certificate, but no warranty is provided.

18.5 In issuing this Certificate, the BBA is not responsible and is excluded from any liability to any company, firm, organisation or person, for any matters arising directly or indirectly from:

- the presence or absence of any patent, intellectual property or similar rights subsisting in the product/system or any other product/system
- the right of the Certificate holder to manufacture, supply, install, maintain or market the product/system
- actual installations of the product/system, including their nature, design, methods, performance, workmanship and maintenance
- any works and constructions in which the product/system is installed, including their nature, design, methods, performance, workmanship and maintenance
- any loss or damage, including personal injury, howsoever caused by the product/system, including its manufacture, supply, installation, use, maintenance and removal
- any claims by the manufacturer relating to CE marking.

18.6 Any information relating to the manufacture, supply, installation, use, maintenance and removal of this product/system which is contained or referred to in this Certificate is the minimum required to be met when the product/system is manufactured, supplied, installed, used, maintained and removed. It does not purport in any way to restate the requirements of the Health and Safety at Work etc. Act 1974, or of any other statutory, common law or other duty which may exist at the date of issue or reissue of this Certificate; nor is conformity with such information to be taken as satisfying the requirements of the 1974 Act or of any statutory, common law or other duty of care.